

Services

Ethernet: IP/LAN

Optical Data: C37.94

Serial: RS530/V.35/RS422/RS485/RS232

Voice: FXS/FXO/E&M/Bridging/compression

Other: G.703/OCU/Dry-Contact

Transport

PseudoWire (TDM over IP)

SONET (OC-3)

EoS (Ethernet over SONET)

TDM (T1/E1)

- ❖ Easy Migration
- ❖ Secure NERC/CIP Platform
- ❖ Multi-Service Communications
- ❖ PseudoWire (TDM over IP)
- ❖ Integrated DACS
- ❖ Ethernet / IP / MPLS Support
- ❖ Dependable Communications
- ❖ High Availability
- ❖ Advanced Management
- ❖ Integrated Teleprotection
- ❖ Integrated Serial Server



Technology at work for you

CONNECTING YOUR BUSINESS TO THE TECHNOLOGY RESOURCES YOU NEED

Flexible solutions for your business needs

HIGH FLEXIBILITY - MINIMAL COST

APPLICATIONS

TDM MIGRATION TO IP

Supports all legacy interfaces over Ethernet/IP using IETF standard PseudoWire Emulation (PWE).

Allows legacy traffic connected to the IMACS to be transported over the customer's IP network, instead of over T1/E1. PWE provides a migration path to IP, without need to replace every non-IP based device.

TECHNOLOGY PROVIDING TOTAL END-TO-END SOLUTIONS.



IMACS-8000

Interfaces include:

- Convert traditional analog radio systems to IP
- Convert legacy serial and audio tone based SCADA system to modern IP network
- Convert old FXS/FXO style PBX systems to IP transport without changing the PBX
- Convert old FXS Order Wire systems to transport over an MPLS or IP network
- Convert 2-wire relay control systems to IP transport

The IMACS PWE support is fully redundant using two PWE cards and can take full advantage of layer-3 IP level transport failover features using modern IP routing protocols.

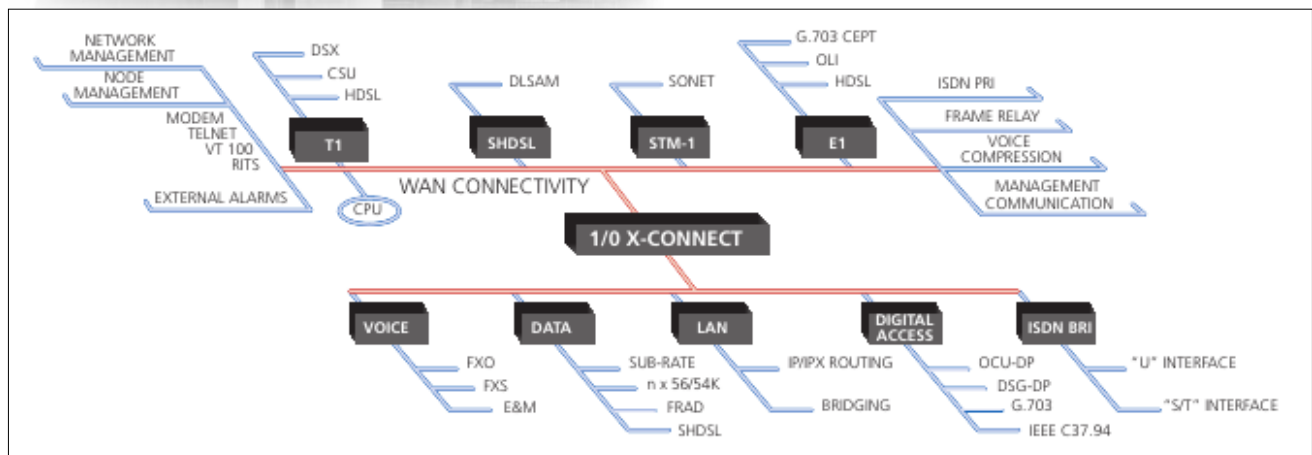

IMACS patented bus architecture simultaneously supports circuit, packet, and cell-switching on a single platform

POWER UTILITIES

Communications are vital for the continuous operation of power plants and the distribution of electricity to customers. Reliable transmission of mission-critical voice and real-time data between power plant control centers and remote sites is required to integrate all processes and services including network management, automation and protection.

Designed for the unique needs of electric utilities, the IMACS supports a wide range of specialty traffic, including teleprotection (e.g., IP, EIA-232 and IEEE C37.94 optical interface to protection relays), SCADA, surveillance video, substation automation and alarms, radio, Ethernet WAN/IP, POTS (E&M/FXS/FXO, ADPCM) and more.

Substation Hardened

The IMACS has been designed to operate in harsh environments such as electric and telephone utility substations and radio communications towers.

- Fanless Operation
- IEEE-1613 Compliant
- GR-63-CORE Issue 1 (NEBS Level 3: Physical)
- GR-1089-CORE Issue 2 (NEBS Level 3: Electromagnetic)
- TR-NWT-000295 Issue 2
- UL 1950

Key benefits of IMACS Sub-Station Communication:

- IEEE-1613 compliant
- Security & reliability
- Simplicity
- Ease of deployment
- Complete System Management
- Powerful Diagnostic and Fault Isolation
- Proven, Approved, Deployed
- Over 150,000 systems worldwide

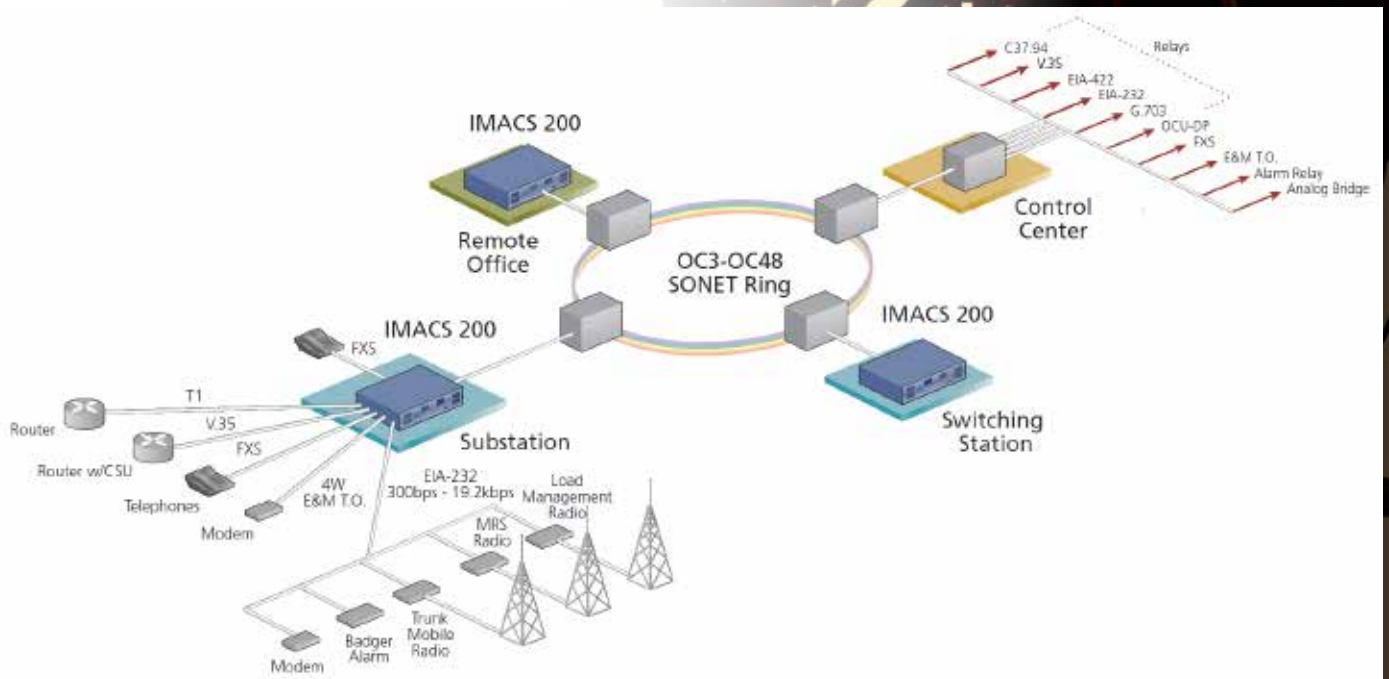

IMACS Substation Application with SONet

NERC SUPPORT

The IMACS includes a wide range of NERC/CIP (Cyber Infrastructure Protection) recommendations for the utility industry.

The included NERC/CIP recommendations are:

Syslog

Remote/off-shelf logging to centralized logging via industry standard SYSLOG protocol. Log data can also be collected via SYSLOG and SNMP on the MegaSys Telenium™ management platform for the IMACS.

NTP

NTP v3 support for accurate time of day for all logs and functions via standard Network Time Protocol.

SSH

Secure login and console access with encryption over the network via Secure Shell (SSH).

Access Control and Authorization

NERC/CIP recommends individual per user and per group privilege levels. The IMACS allows up to 32 distinct privilege levels for system functions including the testing, configuration and routing control of WAN, voice and data circuits for maximum flexibility and protection of the network.

RADIUS Support

Full support for RADIUS, featuring:

- Unlimited number of users*
- Unlimited password complexity*
- Up to 32 different user definable privilege groups -- all 32 IMACS user privilege groups can be mapped to user selectable RADIUS user groups as defined by the RADIUS server supports
- One Time Password tokens such as SecurID™ and CryptoCard™

* user capacity and password complexity is determined by the limits of the RADIUS server used

** SecurID™ or CryptoCard™ are trademarks by their respective owners



HIGHLIGHTS

IPR*4

The IPR*4, or IP Router card provides an integrated 4-port IP/ Ethernet router interface.

The IPR*4 card offers a reliable IP router than can be mapped over TDM or Ethernet interfaces, turning the IMACS -8000 into a modern multiport WAN and LAN router.

Features:

- Up to two cards per shelf
- 4 x RJ-45 Ethernet ports on front panel
- Up to 8 high-speed T1/E1 WAN or 128 single DS0 WAN per card
- Remote management of IMACS CPU via IPR*4
- Support for HDLC or PPP framing



PseudoWire (PWE)

Allows legacy traffic connected to the IMACS to be transported over customer IP network via PseudoWire Emulation (PWE), instead of over T1/E1 TDM based circuits.

The PWE card for the IMACS provides a cost-effective migration path to IP, without the need to replace non-IP based devices.

Features:

- TDM Transport
 - CESoPSN
 - SAToP
 - TDMoIP
- Dynamic IP routing support
- Redundant card support
- Support for adaptive clocking
- Flexible jitter buffer, adjustable to individual customer network requirements



OC-3

The IMACS-8000[†] offers a fully functional OC-3 interface. The IMACS-8000 further enhances the IMACS-8000 interoperability with modern networks by offering up to two redundant OC-3 interfaces for reliable TDM and Ethernet over SONet integration into the customer existing network.

[†] IMACS OC-3 card supported only on IMACS-8000 chassis

Features:

- Redundancy
- 16 Additional add / drop DS1's
- 2 x STS-1 (STS-1-2v) of Ethernet over SONET (EoS)
- Integrated test support



ANALOG BRIDGE CARD

The IMACS offer an integrated full feature audio bridge via the Analog Bridge Card (ABC).

Features:

- High quality DSP engine to combine audio
- Receive and transmit level control (TLP) adjustable per bridge and per port
- Up to two cards per shelf (redundant or independent configurations supported)
- Up to 80 bridges per card
- Up to 240 DS0 aggregate across all bridges
- Bridge remote timeslots as well as local audio ports
- Built-in echo cancellation

NETWORK MANAGEMENT

Telenium Gold and Telenium Gold 365 network management for IMACS (based upon the award winning MegaSys Telenium™ product) provides customers with the fastest and most complete network management software available today. Telenium for IMACS offers all of the functionality of MegaSys Telenium™ with additional IMACS specific features, such as graphical presentation of the IMACS and every known card type, full SNMP support of every configuration item and setting and a full range of IMACS specific alarms.

Using Telenium Gold for IMACS allows your IMACS network to reach its full potential by providing unsurpassed processing power, network management capabilities, scalability and database growth opportunities. Structured on a high-performance object oriented database, Telenium Gold for IMACS provides essential features including auto-population of network architecture, circuit management capabilities, high throughput alarm processing, network element backup and more!



Telenium Gold for IMACS provides full remote management capabilities

Key benefits of MegaSys Telenium™ Management platform for the IMACS

- Auto-configuration
- Auto-Healing
- Alarm Monitoring & History
- Point-and-Click Provisioning
- Remote Upgrade, Backup & Restore
- Powerful Diagnostic and Fault Isolation

Features:

Telenium Gold

- **Windows based GUI**
Easy to use MS Windows based client GUI
- **RHEL based server**
Red Hat enterprise Linux (RHEL) 6 based management server.
- **Alarm Monitoring and history**
Color code each IMACS node according to status (green, red, yellow, black, etc.)
- **Point-and-Click Provisioning**
Click on any existing IMACS node and graphically adjust any and all settings and parameters such as line speed, port mappings, etc..
- **Remote IMACS firmware updates**
Upgrade or downgrade all module cards to any desired firmware version.
- **Remote IMACS configuration backup / restore**
Backup and restore configuration for any node across the network using the GUI.
- **Circuit level testing and maintenance**
Initiate circuit level testing for any service from a single DSO to a full STS-3 pipe featuring a wide variety of diagnostic tests and statistics.

Telenium Gold 365

All of the features of Telenium Gold, plus

- **Auto-Configuration**
Automatically configure services spanning multiple IMACS nodes by graphically selecting start and end nodes and MegaSys Telenium™ will automatically determine an appropriate path of indicate there are insufficient timeslots available.
- **Auto-healing**
Automatically reroute traffic after an outage to the best available path. Services can be prioritized in order of importance.

IMACS OVERVIEW

About the IMACS

The IMACS designed and manufactured in the US, is a flexible and scalable integrated access solution with support for 8 T1/E1 (full cross connect), providing a robust set of voice and data access services and applications on one manageable platform. In addition, the IMACS offers a powerful array of integrated network diagnostic and fault isolation capabilities.

Why the IMACS?

IMACS Solutions are installed worldwide for mission critical applications including electric, gas and water utilities, public safety, transportation and the military. With over 150,000 systems installed worldwide, the IMACS has earned the reputation as a reliable versatile platform.

IMACS

IMACS products are consistently praised for their ease of use and built in diagnostic capabilities. The IMACS carries this tradition forward along with improved backplane resiliency and additional management capabilities combined with an all new graphical management interface co-developed with MegaSys Enterprises, LTD. The IMACS maintains a built in cross connect fabric, eliminating the need for separate DACS equipment and reducing space, CAPEX and OPEX requirements.

The IMACS allows our customers to gracefully migrate to IP solutions with the capability of PWE (Pseudowire) and MPLS while still supporting important traditional interfaces such as RS232, E&M, FXS, FXO, T1/E1 and SONET.

The IMACS offers all the speeds and feeds typically needed at a substation. It is a product that enjoys robust sales, continues to receive significant development and will be in production for many years to come.

Robust Development

The IMACS has evolved beyond the current IMACS capabilities, providing a robust platform to best address the requirements of mission critical applications. New cards provide improved security for NERC/CIP requirements, improved reliability, less downtime as well as significant new features, functions and transport types.

Reduced Maintenance Window

Designed to improve the IMACS uptime. All critical components have been moved to the CPU. The new CPU provides near hitless redundant CPU switchover times. Primary design goal is to provide a more robust platform for mission critical networks, such as public safety and utility sector applications. Service interruption is eliminated or significantly reduced during maintenance periods for all critical services.

Broad Variety of User Interfaces

The IMACS features a variety of user interfaces, including:

- T1/E1
- Ethernet
- FXS/FXO
- E&M (2-wire and 4-wire)
- OCU
- G.703
- IEEE C.37-94
- Serial (RS-530/ V.11/V.35/RS-232/ RS-422/RS-485)

- OVER 50 PLUG-IN SOLUTIONS FOR VOICE, DATA AND IP
- INTEGRATED PROCESSING FEATURES
 - DIGITAL CROSS-CONNECT
 - T1/E1 CONVERSION
 - VOICE COMPRESSION
- OPTICAL HSU INTERFACE TO PROTECTION RELAYS
 - IEEE C37.94
- COMPLETE SYSTEM MANAGEMENT
 - LOCAL AND REMOTE
 - MANAGE UP TO 500 NODES
 - EXTERNAL ALARM MONITORING
- REDUCED MAINTENANCE WINDOW
 - MAINTAIN OR UPGRADE WITH LITTLE OR NO DOWNTIME
- POWERFUL DIAGNOSTIC AND FAULT ISOLATION
 - MULTIPLE TEST PATTERNS, LOOPBACKS AND STATISTICS
- PROVEN. APPROVED. DEPLOYED
 - OVER 150,000 SYSTEMS WORLDWIDE

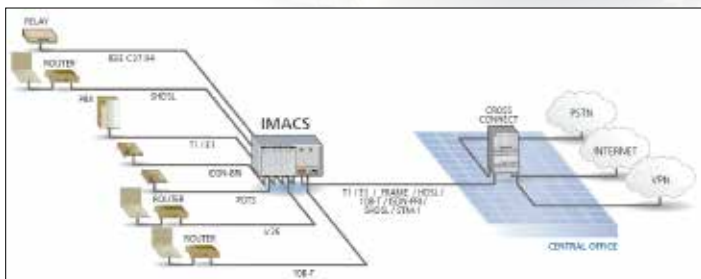

IMACS is unrivaled in network versatility, supporting circuit, packet and cell-switching on a single platform



IMACS provides toll-quality voice compression using industry-standard ADPCM

TECHNICAL SPECIFICATIONS

System Highlights

- Complete system redundancy
- NEBS Level 3 Compliant
- Fully manageable via MegaSys Telenium™ Management system
- Interchangeable set of WAN, subscriber and server cards to match specific applications

Chassis

Model 8000

- 9.12 in. x 17 in. x 15.3 in. /
23.16 cm x 43.2 cm x 38.86 cm (HWD)

Model 3000

- 5.25 in. x 17.5 in. x 15.5 in. /
13.34 cm x 44.45 cm x 39.4 cm (HWD)
- * Leading edge is 18.25 in / 46.36 cm
- * Model 3000 specifications subject to change

Model 3000 (With optional fan shroud)

- 7 in. x 17.5 in. x 15.5 in. /
17.78 cm x 44.45 cm x 39.4 cm (HWD)
- * Leading edge is 18.25 in / 46.36 cm
- * Model 3000 specifications subject to change

Power

Model 8000

- 120 / 240 VAC
- -48 VDC
- Output Power: 55W & 135W continuous
- AC-to-DC power converter (-48 VDC)
- Dual feed & redundancy
- Ring generation (*redundant optional*)

Model 3000

- -48 VDC
- Output Power: 100W continuous
- Dual feed & redundancy
- Ring generation

Applications

- PseudoWire
- Analog voice (FXS, FXO, E&M)
- Voice compression
- Automatic call center distribution connectivity
- Fractional T1/E1
- LAN services / Ethernet
- T1/E1 conversion

Interfaces

- OC-3 (*8000 only*)
- T1/E1
 - 8000: up to 8 local & 16 terminate
 - 3000: up to 6 local
- V.35, RS-530, RS-232, RS-449, RS-422, V.24
- DDS
- SLC96
- IP/Ethernet Router
- IEEE C37.94

Standards Compliance

- ANSI 310-D
- UL 459, 1459, 1950
- Bellcore GR-1089-core, TR-NWT-000295
- Bellcore TR-TSY-000008
- CE EN 50081-1, 50082-1, EN 50022, EN 60950/A2
- FCC part 68, FCC part 15, CTR 12, CTR 13, ACA T5016, IEC 297-1
- ANSI T1.101, T1.107
- ITU-G.703, G.704, G.732, G.735, G.736, G.823, G.824, G.711, G.726
- RFC 1769 (SNTP)
- RFC 2865 (RADIUS)
- RFC 5424 (Syslog)
- RFC 802.3u (10BASE-Tx)
- RFC 802.3i (10BASE-Tx)

Management Interfaces

- Connectivity: Craft (RS232), Telnet, SSH, modem, SLIP/PPP, FDL time slot 24 (T1) or SAA time slot 31 (E1)
- Interface: SNMP

Management System

- MegaSys Telenium™
- Operates on VirtualBox or RHEL 6
- SNMP-based
- Centralized management of IMACS
- Point & Click graphical user interface
- Auto-Configuration
- Auto-Healing
- Management of configurations, alarms, connectivity & diagnostics
- Multi-user environment

Environmental

- Fanless operation (*8000 only*)
- IEEE-1613 compliant

Clocking

- Stratum 4
- Sources: internal, T1, E1, digital interface, external clocking

Redundancy

- CPU
- Power supply
- WAN interfaces
- OC-3
- ADPCM
- Audio Bridge
- Alternate Map Table (AMT)
- PWE Card



Product Source International Datacomm, LLC
330 Franklin Turnpike
Mahwah, NJ 07430
201.488.6000 Tel
www.psitec.com / sales@psitec.com



DASAN Zhone Solutions, Inc.
7195 Oakport Street
Oakland, CA 94621
510.777.7000 Tel
www.dasanzhone.com

DASAN Zhone Solutions, Inc. (NASDAQ: DZSI) is the first company dedicated solely to delivering the full spectrum of next-generation wireline infrastructure equipment. DASAN Zhone's Single-Line Multi-Service architecture (SLMS™), allows carriers to concurrently deliver voice, new premium data and video services over copper or fiber access lines. DASAN Zhone provides carriers with an elegant migration from legacy circuit-based technology to packet based networks while substantially reducing operating costs. With deployments at over 300 carriers including among some of the world's largest networks, DASAN Zhone has enabled carriers to reinvent their businesses. For more information, please visit:
www.dasanzhone.com

Copyright 2018 DASAN Zhone Solutions, Inc. All rights reserved. DASAN Zhone™, the DASAN Zhone logo, and all DASAN Zhone product names are registered trademarks of DASAN Zhone Solutions, Inc.

Copyright 2018 - 1995 MegaSys Enterprises Ltd. © 2018 - 1995 Worth Ventures Ltd. All Rights Reserved. MegaSys® and Telenium® are registered trademarks of MegaSys Enterprises Ltd. Other brand and product names are trademarks of their respective holders. Specifications, products, and/or product names are all subject to change without notice.